

# Brivis 38CXA Series – Installer Manual

**Amendment - Nov 2009** (Replaces Feb 2009)

**This document replaces Section 7 - “Make Electrical Connections”**

**in the Brivis 38CXA Series Installer Manual [P/N: 28YCYB54010-R]**

**This version amends the section on:**

**CONNECTING TO BRIVIS CLASSIC HEATER WITH BRIVIS PROGRAMMABLE [ANALOG] THERMOSTAT**

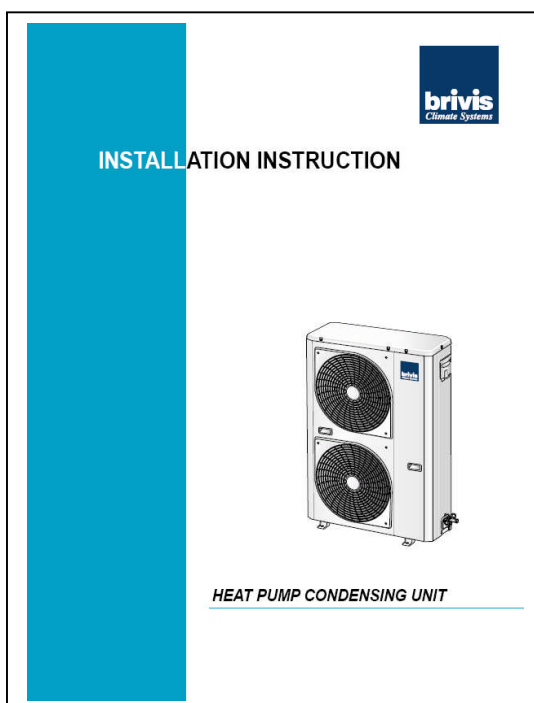

**Please ignore all reference to ‘Heat Pump’ operation in this manual. The Brivis 38CXA Series Units are designed for use as an add-on cooling system to Brivis Ducted Gas Furnaces.**

**For Technical Support please call**

**1300 361 295**

## 7. MAKE ELECTRICAL CONNECTIONS

### IMPORTANT

PLEASE READ SECTION 7 IN ITS ENTIRETY BEFORE PROCEEDING

### NOTE

Be sure field wiring complies with local and national fire, safety and electrical codes, and voltage to system is within limits shown on unit rating plate.

Contact local power company for correction of improper voltage. See table 3 and unit rating plate for recommended circuit protection device and minimum circuit amps for wire size.

### NOTE

Operation of unit on improper line voltage constitutes abuse and could affect unit reliability. See unit rating plate. Do not install unit in system where voltage may fluctuate above or below permissible limits.

### NOTE

Use copper wire only between disconnect switch and the unit.

### WARNING

According to NEC, ANSI/NFPA 70, and local codes the cabinet must have an uninterrupted or unbroken ground, to minimize personal injury if an electrical fault should occur. The ground may consist of electrical wire or metal conduit when installed in accordance with existing electrical codes. Failure to follow this warning could result in an electric shock, or death.

### 1) GROUND AND POWER WIRES

- All electrical connections must be performed by a licensed electrician.
- All wiring must comply with relevant wiring regulations and any local requirements.
- Unit wiring label is situated inside unit access cover.
- Provision **MUST** be made to incorporate an ISOLATING switch of adequate size within sight of the unit or a switch of the type that may be locked open (OFF) into unit wiring.
- Route power wires through opening below the access cover and connect in unit control box as show on unit wiring diagram and Figure 5.
- Unit must be grounded.

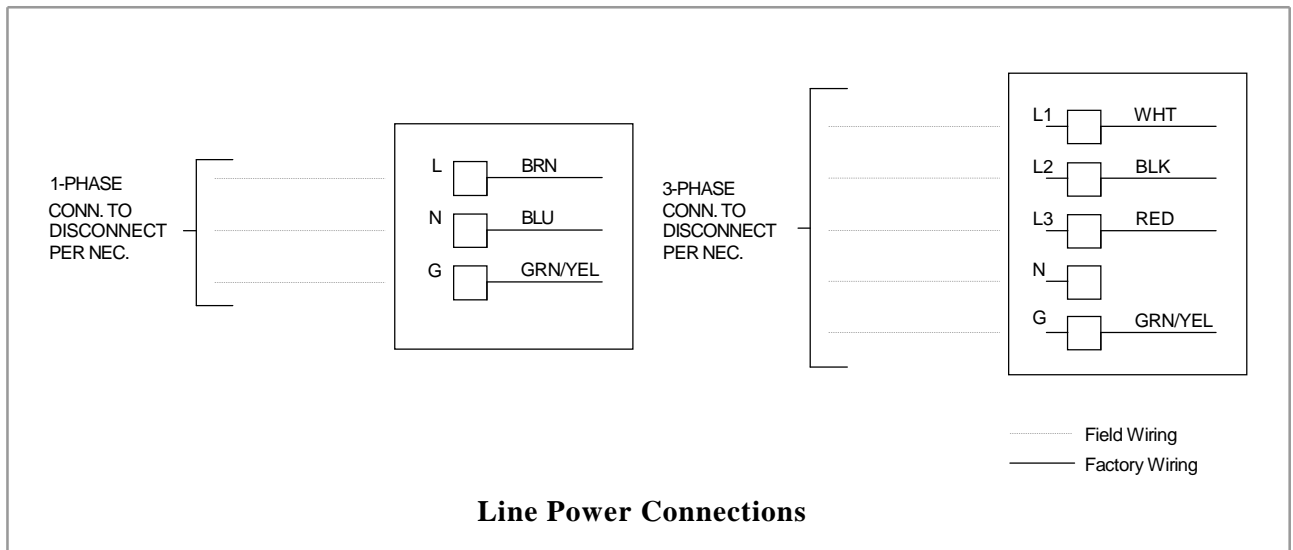

Figure 5

**TABLE 3. ELECTRICAL DATA**

MODEL	Volts-ph-Hz	Max. Demand		Fuse Amps HRC or Circuit Breaker
		Amps	kW	
38CXA10-7	240-1-50	17	3.41	20 (See NOTES below)
38CXA12-7	240-1-50	19	4.01	30 (See NOTES below)
38CXA14-7	240-1-50	22	4.34	35 (See NOTES below)
38CXA14-9	415-3-50	10	4.53	15 (See NOTES below)
38CXA17-9	415-3-50	14	5.39	20 (See NOTES below)

\*Unit will operate satisfactorily 10% above or below unit rated nameplate voltage.

**NOTE**

All HRC fuses or circuit breakers must be motor rated.

## 2) CONTROL CIRCUIT WIRING – 38CXA AS AN ADD-ON SYSTEM

Control voltage is 24 volts (40VA min.) Use No. 16 AWG color coded wire to avoid excess voltage drop.

To access the Terminal Strip on the "NR-1" PCB, remove the top cover of the condensing unit.

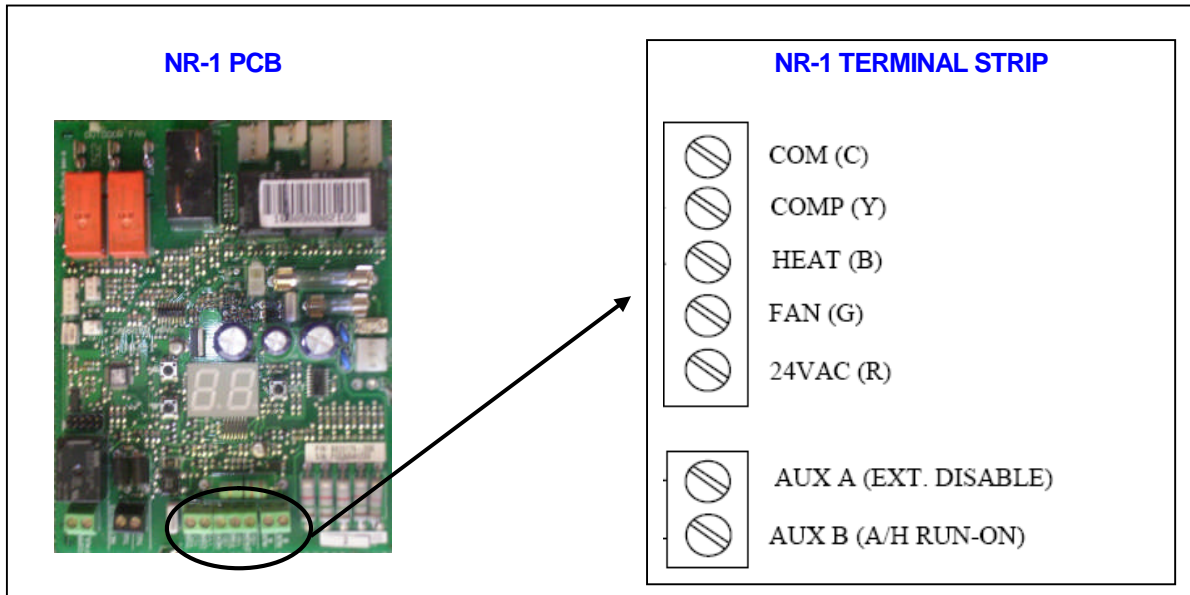

### CONNECTING TO BRIVIS MPS (HE or ME) HEATER

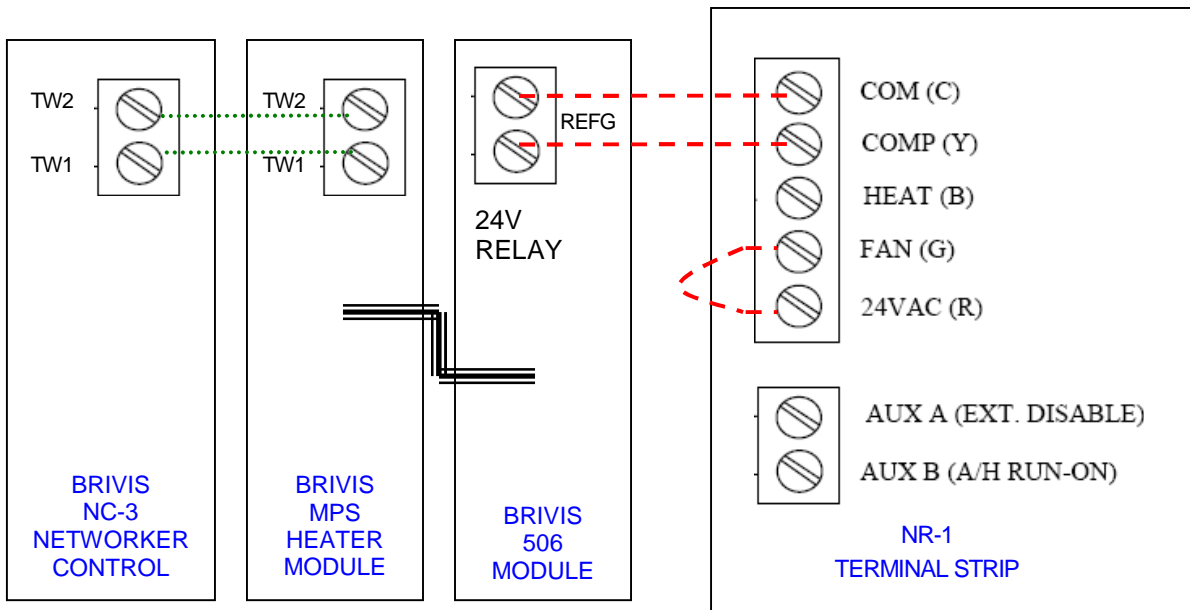

LOOM CONNECTING THE BRIVIS 506 MODULE TO THE BRIVIS MPS HEATER MODULE

24V Field Wiring

2 WIRE BUS Field Wiring

**CONNECTING TO BRIVIS CLASSIC HEATER  
WITH BRIVIS PROGRAMMABLE [ANALOG] THERMOSTAT  
[BCG-1 or BCG-3 Controller – Classics Pre-October 2007]**

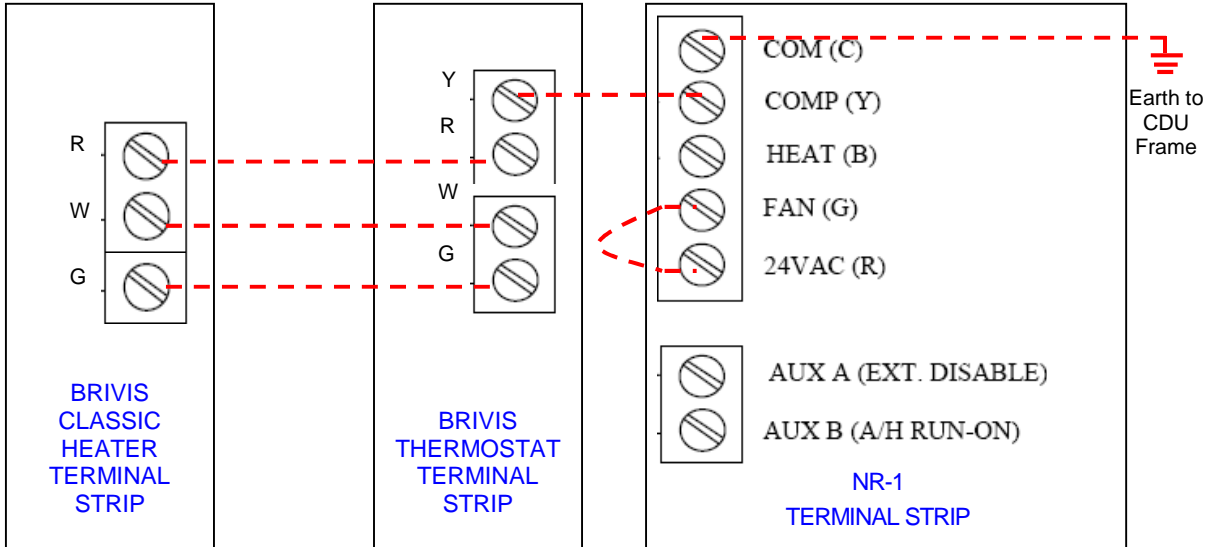

**CONNECTING TO BRIVIS CLASSIC HEATER  
WITH BRIVIS PROGRAMMABLE [ANALOG] THERMOSTAT  
[HCCA621 Controller – Classics Post-October 2007]**

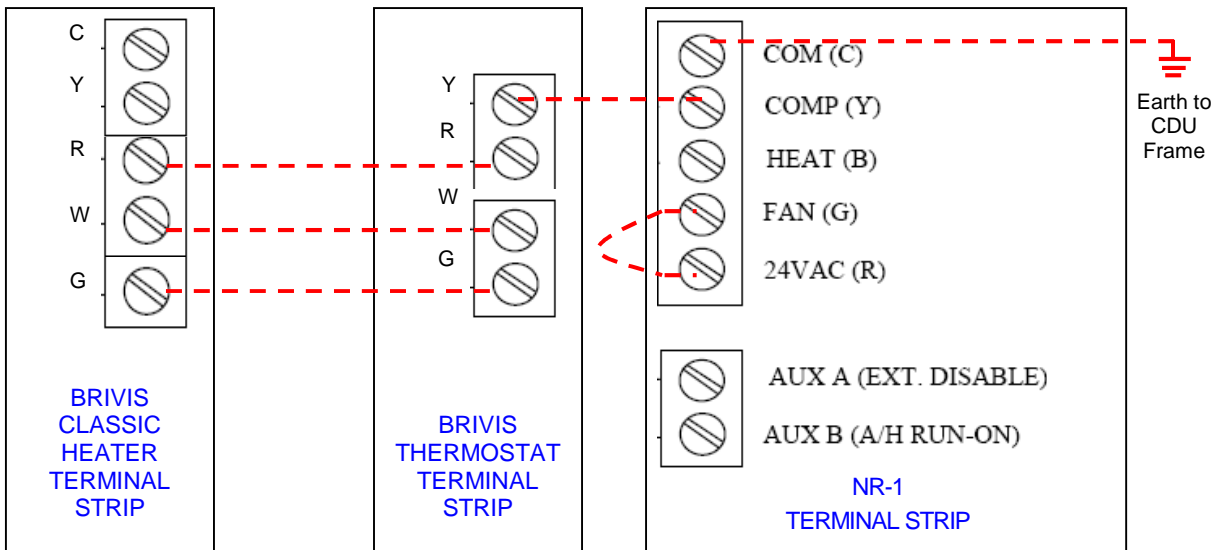

----- 24V Field Wiring

## **IMPORTANT NOTES**

The MAINS Terminal Strip behind the side cover is for MAINS POWER ONLY

To access the 24V Terminal Strip on the NR-1 PCB, remove the top cover of the condensing unit. Take care when reassembling – ensure lid is correctly installed before operating

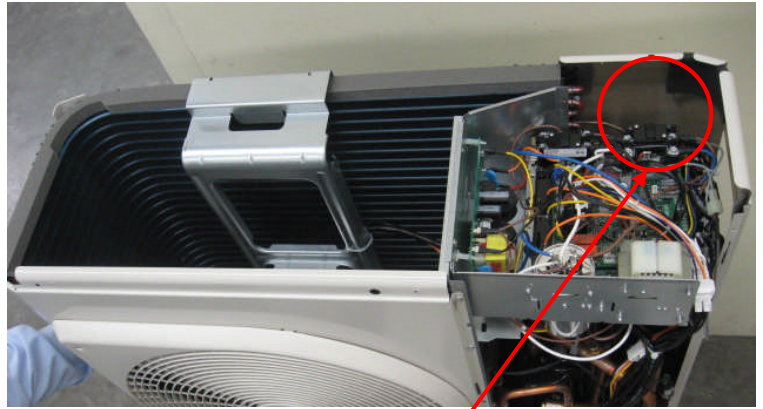

Pictures show 38CXA Single Phase Unit

DO NOT USE Terminals labeled 'FCU FAN MOTOR' or 'NETWORKER (NC-4)'

NR-1 PCB